

TONDO COMPACT

Waschtisch aus Metall mit vorgebohrtem Hahnloch, aus Edelstahl AISI 304, mit integrierten Handtuchhaltern und Ablage. Inklusive VetroFreddo®-Waschtisch mit verchromter Ablaufgarnitur (mit Set für Pop-up-Option ausgestattet).

Metal washstand with pre-drilled tap hole, fashioned in stainless steel AISI 304 with integrated towel holders and shelf. VetroFreddo® washbasin with chrome free flow waste (equipped with set for pop-up option) included.

Artikel: Tondo Compact

Kategorie: Waschtisch

Material: Acciaio AISI 304/
VetroFreddo®

Gewicht: kg ±9,00

Article: Tondo Compact

Category: Metal washstand

Material: Stainless steel AISI 304/
VetroFreddo®

Weight: kg ±9,00

FARBEN Lavabo/Struttura
COLOURS Washbasin / Washstand

white mat / black mat

TONDOCOMPNOPO01



black mat / white mat

TONDOCOMPBOPO30



black mat / black mat

TONDOCOMPNOPO30



gold leaf 3d / white mat

TONDOCOMPBOFO



gold leaf 3d / black mat

TONDOCOMPNOFO



silver leaf 3d / white mat

TONDOCOMPBOFA



silver leaf 3d / black mat

TONDOCOMPNOFA



avio / white mat

TONDOCOMPBOPO402



avio / black mat

TONDOCOMPNOPO402



cedro / white mat

TONDOCOMPBOPO102



cedro / black mat

TONDOCOMPNOPO102



powder pink / white mat

TONDOCOMPBOPO202



powder pink / black mat

TONDOCOMPNOPO202



sage green / white mat

TONDOCOMPBOPO302



sage green / black mat

TONDOCOMPNOPO302



Inkl. Ablaufventil Chrom. Flexibler Ablauf RACCORDO joint ist zwingend erforderlich.

Incl. drain valve chrome. Flexible drain RACCORDO joint is mandatory.

Handgefertigtes Produkt, die Abmessungen können leicht variieren. Handcrafted product, dimensions subject to small variations.

white mat / old brass

TONDOCOMPBOPO01



black mat / old brass

TONDOCOMPBOPO30



TECHNISCHE DATEN

TECHNICAL DATA

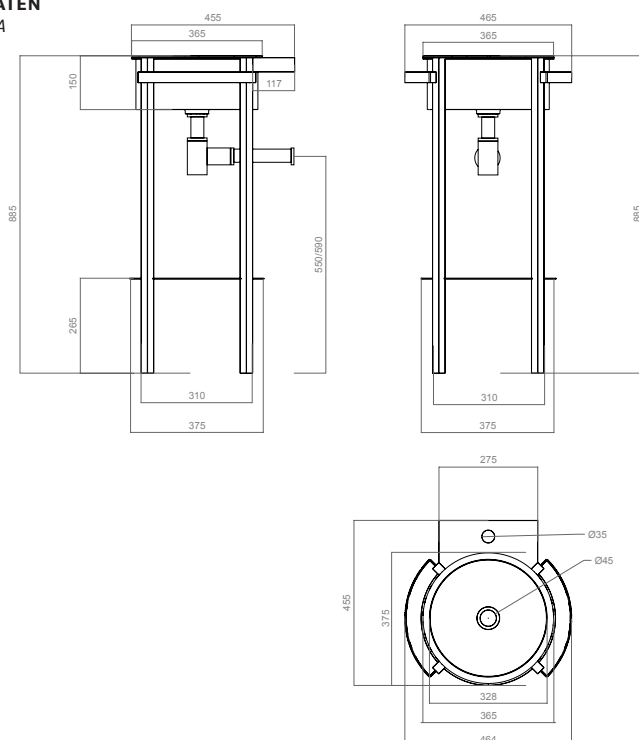

WASCHTISCH MIT WANDBEFESTIGUNG
WASHSTAND WITH WALL FIXING

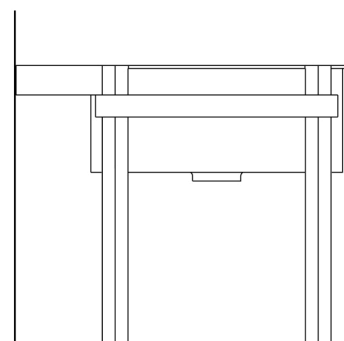

SPEZIFIKATIONEN
SPECIFICATIONS

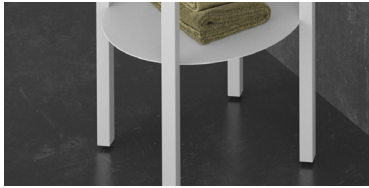

FÜSSE UND ABLAGE -
Verstellbare Füße, integrierte
Handtuchhalter und Ablage.

*FEET AND SHELF - Adjustable
feet and integrated towel
holders and shelf.*

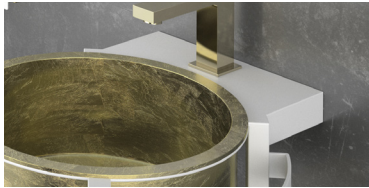

WASCHBECKEN
Waschbecken
VetroFreddo[®]

*WASHBASIN - VetroFreddo[®]
washbasin*

MÖBELMONTAGE
FURNITURE INSTALLATION

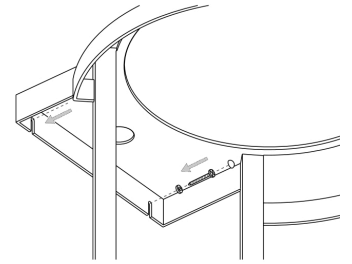

- 1) Den Waschtisch an der Wand befestigen.
1) Fix the washstand to the wall.

weitere Informationen finden Sie auf
dem Montageblatt
*for other information consult the
assembly sheet*

PFLEGE UND REINIGUNG
CARE AND MAINTENANCE

Bitte reinigen Sie die Produkte nur mit Wasser und neutraler Seife unter Verwendung weicher Tücher. Verwenden Sie auf keinen Fall Reinigungsmittel, die Scheuermittel oder aggressive Substanzen enthalten. Eine unsachgemäße Reinigung kann die Oberfläche der Produkte dauerhaft beschädigen; in diesem Fall kann das Unternehmen nicht für Schäden haftbar gemacht werden.

Please clean the products with water and neutral soap only, using soft towels. Do not use for any reason cleaning solutions containing abrasive or aggressive substances. Incorrect cleaning may permanently ruin the surface of the products and in such case the company may not be held liable for damage.

GELIEFERTE KOMponentEN
COMPONENTS SUPPLIED

- Schrauben (mit Gummidichtung)
Screws (with rubber rings)
- Schraubenabdeckung
Screw cover
- Dübel
Bolts

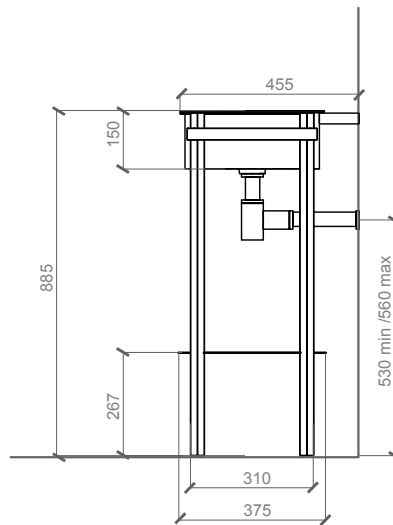

Bevor Sie mit der Installation fortfahren, überprüfen Sie die die korrekte Positionierung des Wassersystems.
Before proceeding with the installation, check the correct positioning of the water system.

1.

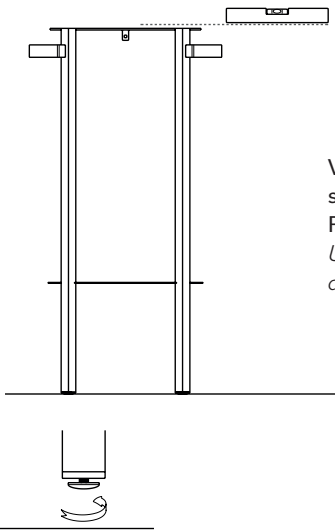

Verwenden Sie die verstellbaren Füße, um den Rahmen anzupassen.
Use the adjustable feet to adapt the structure.

2.

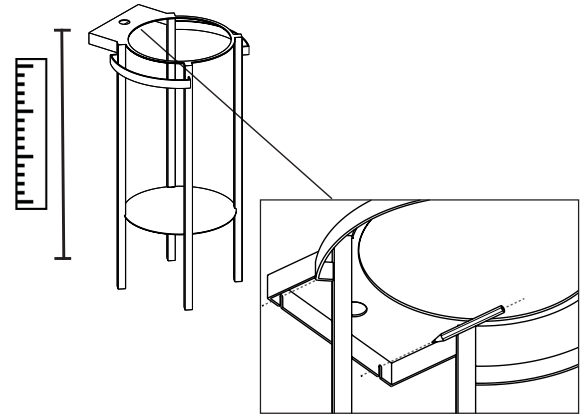

Stellen Sie den Waschtisch nahe an die Wand und markieren Sie die 2 Befestigungspunkte an der Wand.
Place the washstand unit close to the wall and mark the 2x fixing points to the wall.

3.

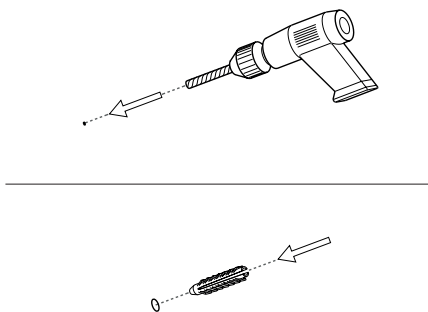

Bohren Sie das markierte Loch und setzen Sie den Dübel in das Loch ein.
Drill the marked hole and insert the bolt into the hole.

4.

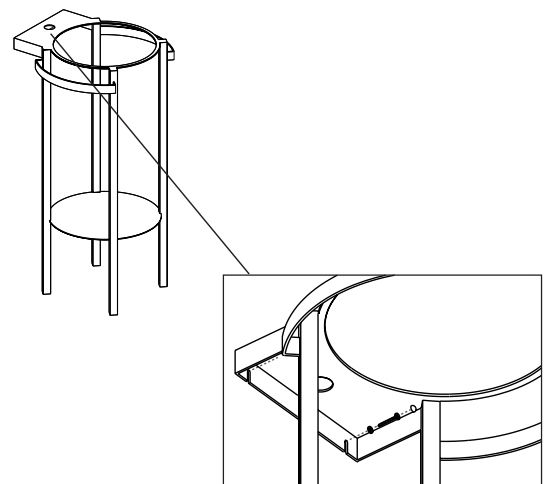

Stellen Sie den Waschtisch an die Wand und verwenden Sie die mitgelieferten Schrauben um das Gestell an der Wand zu befestigen.
Place the washstand unit against the wall and use the supplied screws for wall fixing.

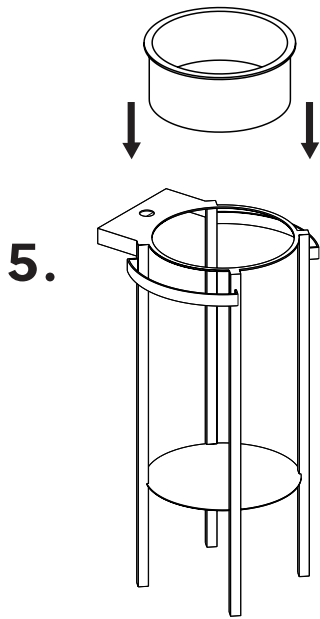

Setzen Sie das Waschbecken
in das Metallgestell.
*Place the washbasin into the
metal furniture.*

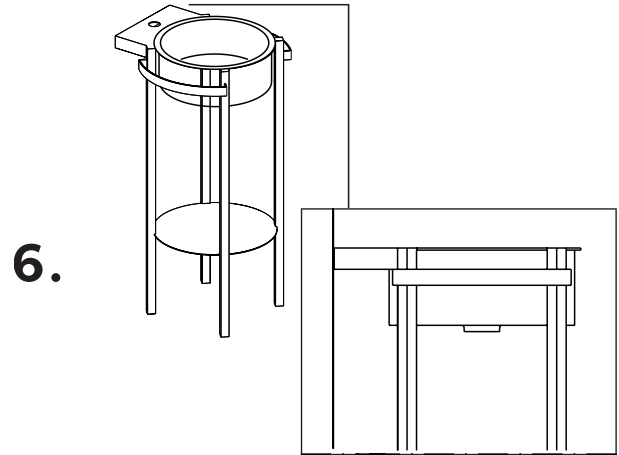

Stellen Sie den Waschtisch nahe an die Wand und mar-
kieren Sie die 2 Befestigungspunkte an der Wand.
*Place the washstand unit close to the wall and mark the
2x fixing points to the wall.*